

SF-JRV 63M~132M & SF-JV 160M~180L VERTICAL TYPE

Totally Enclosed Fan Cooled Type, IP 55 Degrees of Protection



SF-JRV 10HP 4P 132M

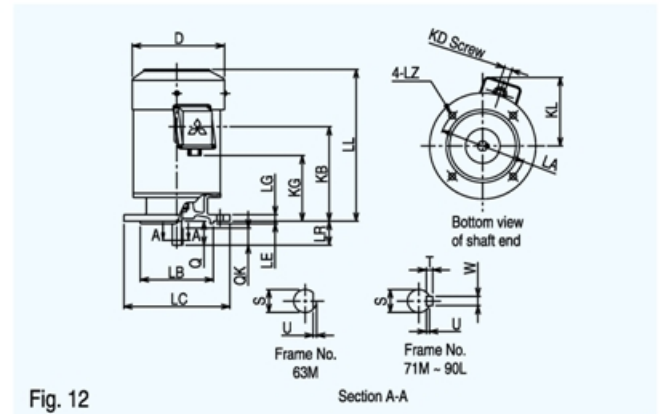

Fig. 12

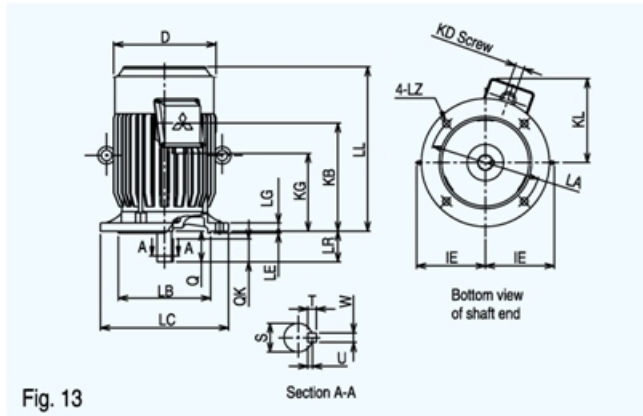

Fig. 13

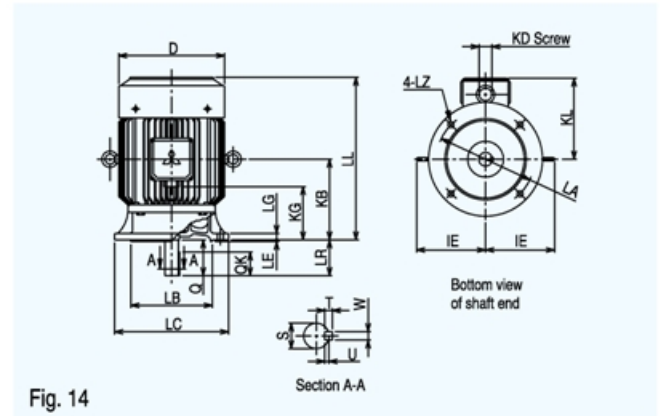

Fig. 14

Dimensions (mm)

Model	Flange No.	Frame No.	Output HP (kW)			Fig.	Motor								Terminal Box			
			2-Pole	4-Pole	6-Pole		D	IE	LA	LB	LC	LE	LG	LL	LZ	KD	KG	KL
SF-JRV	FF130	63M	1/4(0.2)	1/4(0.2)	-	12	127	-	130	110 j6	160	3.5	10	208	10	PF1/2	58	125
	FF130	71M	1/2(0.4)	1/2(0.4)	1/4(0.2)		148	-	130	110 j6	160	3.5	10	229	10	PF1/2	80	138
	FF165	80M	1(0.75)	1(0.75)	1/2(0.4)		166	-	165	130 j6	200	3.5	12	226	12	PF3/4	78	144
	FF165	90L	2(1.5), 3(2.2)	2(1.5)	1(0.75)		186.3	-	165	130 j6	200	3.5	12	288.5	12	PF3/4	133	156
	FF215	100L	-	3(2.2)	2(1.5)	13	207	130	215	180 j6	250	4	16	321	14.5	PF3/4	148	169
	FF215	112M	5(3.7)	5(3.7)	3(2.2)		230	141	215	180 j6	250	4	16	351	14.5	PF3/4	174	180
	FF265	132S	7.5(5.5), 10(7.5)	7.5(5.5)	5(3.7)		266	156	265	230 j6	300	4	20	392.5	14.5	PF1	173	213
	FF265	132M	-	10(7.5)	7.5(5.5)		266	156	265	230 j6	300	4	20	430.5	14.5	PF1	211	213
SF-JV	FF300	160M	15(11), 20(15)	15(11)	10(7.5)	14	324	213	300	250 j6	350	5	20	500	18.5	PF1 1/4	147	259
	FF300	160L	25(18.5)	20(15)	15(11)		324	213	300	250 j6	350	5	20	544	18.5	PF1 1/4	169	259
	FF350	180M	30(22)	25(18.5), 30(22)	20(15)		376	247	350	300 j6	400	5	20	576	18.5	PF1 1/2	176	284
	FF350	180L	40(30)	40(30)	25(18.5), 30(22)		376	247	350	300 j6	400	5	20	614	18.5	PF1 1/2	195	284

Model	Flange No.	Frame No.	Shaft End				Bearing No.		Approximate Weight (kg)			Approximate Packing Dimensions (LxWxH)	Packing Weight (kg)					
			LR	Q	QK	S	T	U	W	Drive End	Opposite		2-Pole	4-Pole	6-Pole	2-Pole	4-Pole	6-Pole
SF-JRV	FF130	63M	23	23	-	11 h6	-	1	-	6201ZZ	6201ZZ	6.5	6.6	-	318 x 256 x 180	6.8	6.9	-
	FF130	71M	30	30	25	14 j6	5	3	5	6202ZZ	6201ZZ	8.0	9.2	9.0	318 x 256 x 180	9.3	9.8	9.4
	FF165	80M	40	40	32	19 j6	6	3.5	6	6204ZZ	6203ZZ	12	13	13	368 x 280 x 226	13	14.5	13.5
	FF165	90L	50	50	40	24 j6	7	4	8	6205ZZ	6204ZZ	19.5, 23	22.5	21.5	425 x 280 x 226	19.6, 23.8	23	22.5
	FF215	100L	60	60	45	28 j6	7	4	8	6206ZZ	6205ZZ	-	28	29	456 x 355 x 300	-	29.5	31.5
	FF215	112M	60	60	45	28 j6	7	4	8	6207ZZ	6206ZZ	37	40	42	507 x 401 x 357	44	47	49
	FF265	132S	80	80	63	38 k6	8	5	10	6308ZZ	6207ZZ	55, 63	56	58	569 x 459 x 386	63, 71	64	66
	FF265	132M	80	80	63	38 k6	8	5	10	6308ZZ	6207ZZ	-	66	68	637 x 459 x 386	-	74	76
SF-JV	FF300	160M	110	110	90	42 k6	8	5	12	6309ZZ	6308ZZ	110, 120	110	110	778 x 602 x 557	134, 144	134	134
	FF300	160L	110	110	90	42 k6	8	5	12	6309ZZ	6308ZZ	150	140	140	822 x 602 x 557	174	164	164
	FF350	180M	110	110	90	48 k6	9	5.5	14	6311ZZ	6310ZZ	195	190, 200	200	854 x 652 x 610	222	217, 227	227
	FF350	180L	110	110	90	55 m6	10	6	16	6312ZZ	6310ZZ	225	235	225, 240	892 x 652 x 610	252	262	252, 267